

AL'S 790-460 (SP)

3 Manholes

Model 790-460 Septic-pump

791 Gal. Septic 460 Gal Pump

378 G.P.D. When Used As A Septic/Pump Or Septic/Siphon Based On A 3 Yr. Service Interval.

96" depth of bury

DIMENSIONS:

Length: 9'4"

Width: 7'0"

Height: 58"

Below Inlet: 42"

Below Outlet: 40"

Tank Weight: 7153 lbs.

Cover Weight: 4114 lbs.

Total Weight: 11267 lbs.

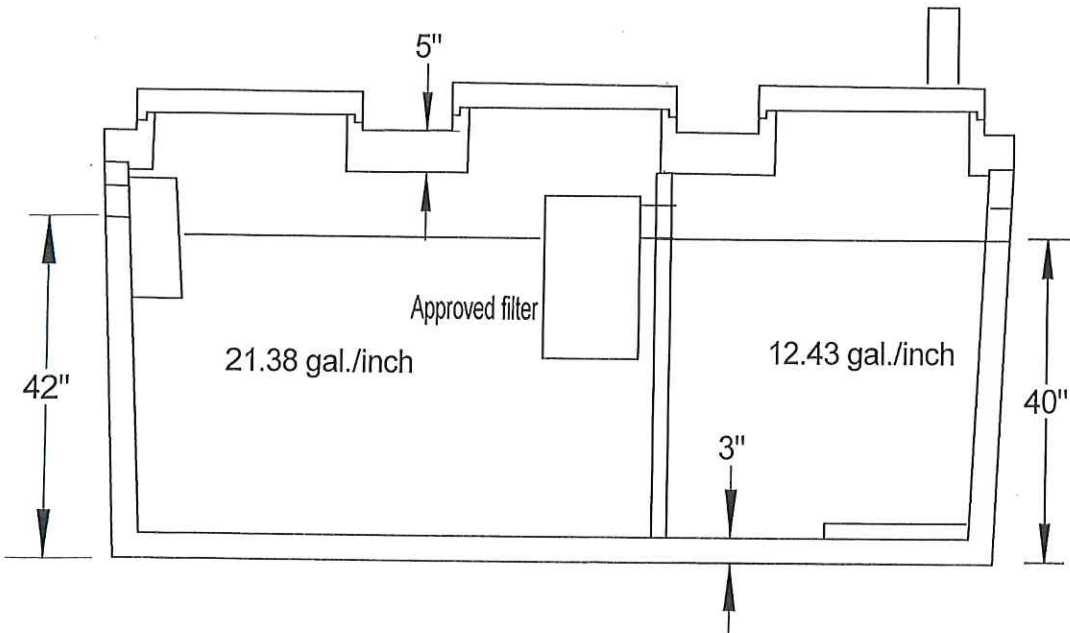

AL'S Concrete Products, Inc.
 800 Townhall Road . La Crescent, MN 55947
 507-895-4509 1-800-982-9263 507-895-6805 Fax
www.alsconcreteproducts.com